

RENEWABLE SEALING AUGER CASE

Pug Sealer auger case liner segments are long-wearing and replaceable.

When it's time to replace a worn sealing auger split casing on your 75 or 90 Pug Sealer, consider replacing it with the Steele Renewable Sealing Auger Case. Like the original split casing, it's made in two halves to aid installation - but with one major difference: 12 wear-resistant 28PC liner segments (and not the case itself) are replaceable. You get much more wear life and lower maintenance costs.

Steele has been refining clay machinery for more than 100 years. The Steele Renewable Sealing Auger Case reflects that attention to detail and commitment to continuous improvement.

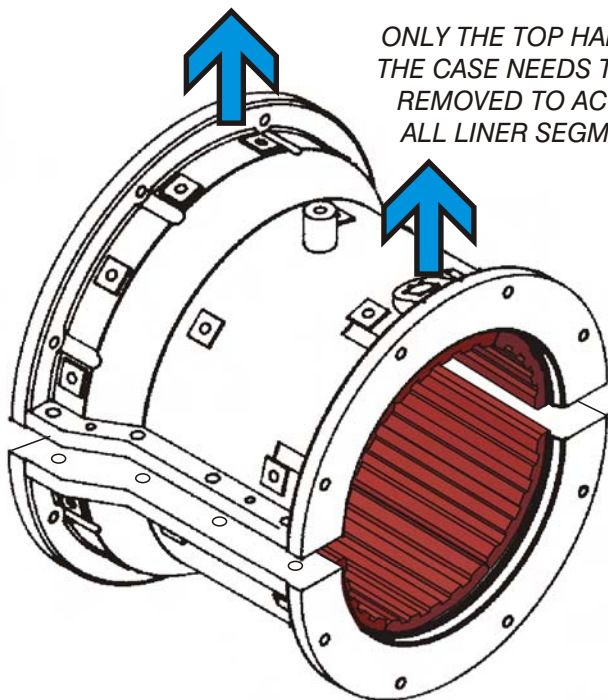
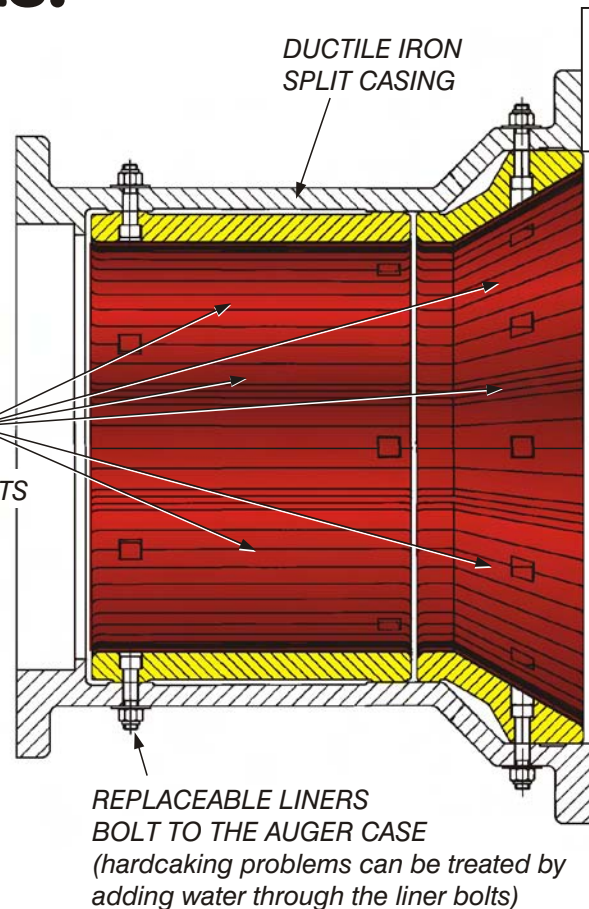

ONLY THE TOP HALF OF THE CASE NEEDS TO BE REMOVED TO ACCESS ALL LINER SEGMENTS

CALL STEELE FOR DETAILS ON THE CONVERSION KIT:

ITEM	DESCRIPTION	QTY
48B-TOP	Top half of sealing auger case	1
48B-BOTTOM	Bottom half of sealing auger case	1
48BLF	Front Liners (28PC)	6
48BLR	Rear Liners (28PC)	6
-	Bolts, nuts, and copper washers	24



The Best in Clay Machinery Since 1889

J.C. STEELE & SONS, INC.

P.O. Box 1834 • Statesville, NC USA 28687

TEL: (704) 872-3681 • FAX: (704) 878-0789

Call Toll-Free (US only): 800-278-3353 www.jcsteele.com